

# MANIACCESS

# 120 AETJ 120 AETJ 3D

Concentrated technology



# The 120 AETJ :

## A narrow machine with outstanding outreach

Because making the best use of space is becoming more and more important, Manitou has produced the 120 AETJ.

The 120AETJ is a compact electric articulating boom (working height 12m), specially designed for all your maintenance and logistical operations.

### Very compact

With an overall width of only 1.2 metres and a stowed height of less than 2.0 metres enables the **120 AETJ** to access any building fitted with standard doorways.



Inside and outside use

Working outreach : 7 m

### The best outreach in its class

This impressive outreach for a narrow machines enables it to overcome most obstacles and hard to reach places.

As standard the zero-tail swing plus the optional extra of the 3 dimensional suspended arm system, enables the **120 AETJ 3D** to access most places by increasing the working envelope of the machine.



# ENTER THE THIR



## Safety

- Hydraulic anti-roll system: activated as soon as the arm is lifted to guarantee maximum safety for the operator.
- 10 cm ground clearance in “transport” mode.



## Comfort

- Spacious basket: allows 2 operators to work in good conditions.
- Twin handrails to protect hands.
- Tool-tidy allows equipment to be put down safely.



## Fittings

- Non-marking tyres as standard, ideal for interior working without leaving marks on your flooring.

**Wide tyres** : leaves fewer impressions on the flooring.



## Easy to use

Control box ergonomically designed and simple to use.

- **Safety** : the selected operation is cancelled after 8 seconds if the order is not confirmed.
- Electro-proportional movement for smoother and more precise operation.
- Movement selected by push buttons.

# D DIMENSION...



3,74 m

## Convenient

Transport / storage position.

### JIB 3 D

- 140° tilt
- 140° Rotation

## High performance

The 3 dimensional suspended arm enables the **Manitou** access platform to be used on even the most restricted industrial sites.

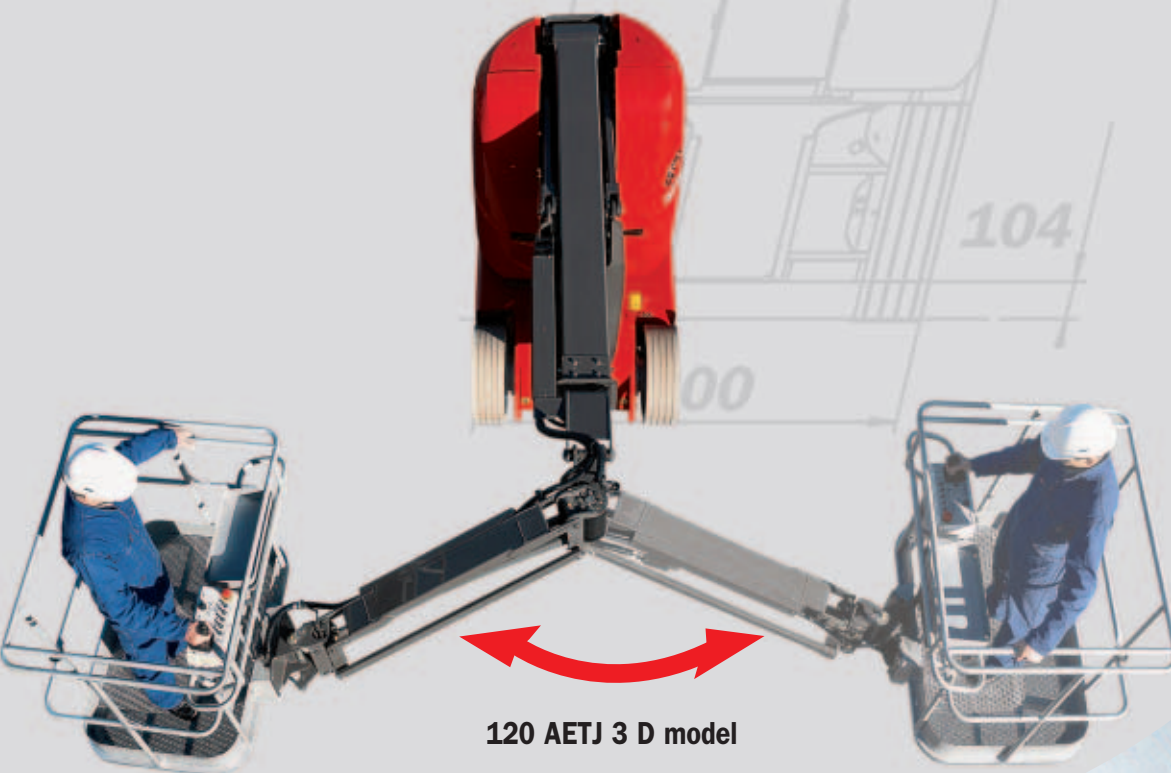
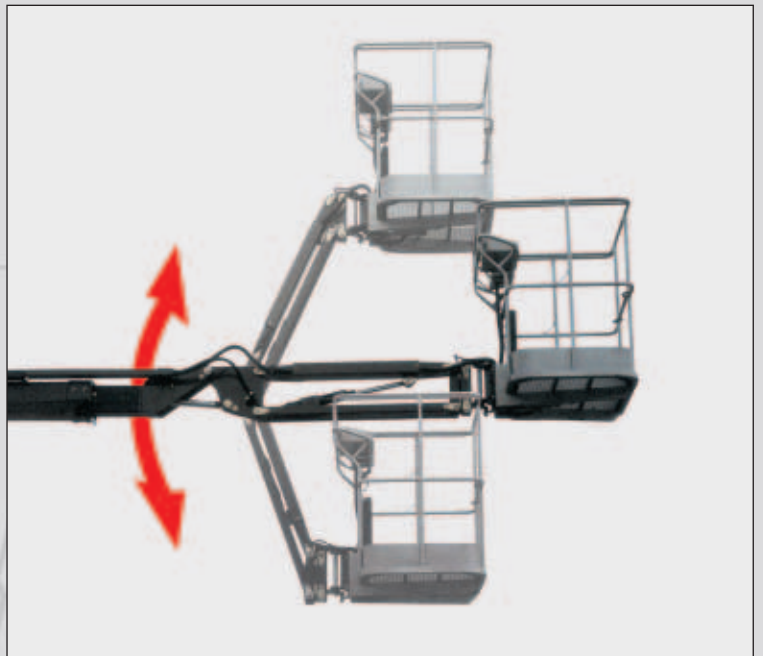

120 AETJ 3 D model

# IDEAL FOR ALL KINDS OF WORK



## Standard Equipment









- Negative brakes
- Lifting brackets
- Hour meter
- Warning buzzer in the basket
- 220 V predisposal
- Voltage indicator
- Basket with mesh floor for better visibility
- Safety lowering systems
- No marking tyres
- Buscan technology
- Diagnostic help integrated in lowered control box
- Electric motors











## Optional Equipments

- Flashing light
- All motion alarm
- Flashing beacon
- Gel type battery
- **Extreme cold condition option**

## 120 AETJ

	<b>Safe Working Load</b> .....230 kg <b>Outside use</b> .....(SWL 120 kg)
	<b>Working height</b> .....11.95 m <b>Platform height</b> .....9.95 m
	<b>Overall length</b> .....5.48 m <b>Length (transport position)</b> .....3.74 m <b>Overall width</b> .....1.20 m <b>Overall height</b> .....1.99 m <b>Basket size</b> .....1.20 x 0.96 m <b>Max. outreach</b> .....7 m/4.77 m <b>Ground clearance</b> .....10 cm <b>Turning radius (inside/outside)</b> .....1.55 m/3.34 m
	<b>Travel speed</b> .....0 to 6 Km/h
	<b>Basket rotation</b> .....140° <b>Turret rotation</b> .....350° <b>Jib tilting</b> .....140°
	<b>Traction battery</b> .....48 V/300 Ah (C5) <b>Integrated charger</b> .....48 V/60 A
	<b>Gradeability</b> .....25% <b>Max. slope accepted</b> .....5% or 3° <b>Hydraulic tank</b> .....12 l.
	<b>Tyres</b> .....no marking - 600 X 190 2 wheel drive (rear) et 2 steering wheel (front)
	<b>Weight</b> .....6550 kg

## 120 AETJ 3D

	<b>Safe Working Load</b> .....230 kg <b>Outside use</b> .....(SWL 120 kg)
	<b>Working height</b> .....11.95 m <b>Platform height</b> .....9.95 m
	<b>Overall length</b> .....5.48 m <b>Length (transport position)</b> .....3.74 m <b>Overall width</b> .....1.20 m <b>Overall height</b> .....1.99 m <b>Basket size</b> .....1.20 x 0.96 m <b>Max. outreach</b> .....7 m/4.77 m <b>Ground clearance</b> .....10 cm <b>Turning radius (inside/outside)</b> .....1.55 m/3.34 m
	<b>Travel speed</b> .....0 to 6 Km/h
	<b>Basket rotation</b> .....140° <b>Turret rotation</b> .....350° <b>Jib tilting</b> .....140° <b>Rotation du jib</b> .....140°
	<b>Traction battery</b> .....48 V/300 Ah (C5) <b>Integrated charger</b> .....48 V/60 A
	<b>Gradeability</b> .....25% <b>Max. slope accepted</b> .....5% or 3° <b>Hydraulic tank</b> .....12 l.
	<b>Tyres</b> .....no marking - 600 X 190 2 wheel drive (rear) et 2 steering wheel (front)
	<b>Weight</b> .....6550 kg

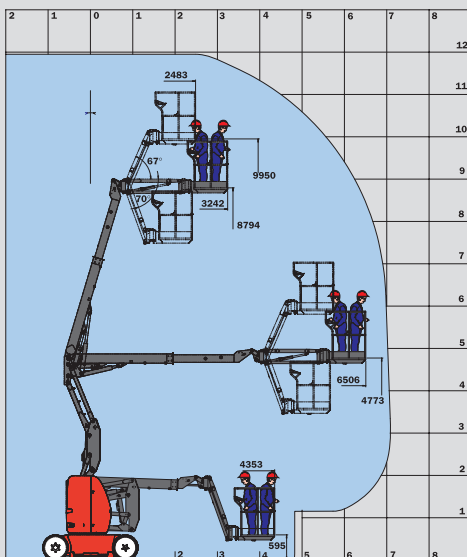

120 AETJ  
120 AETJ 3D

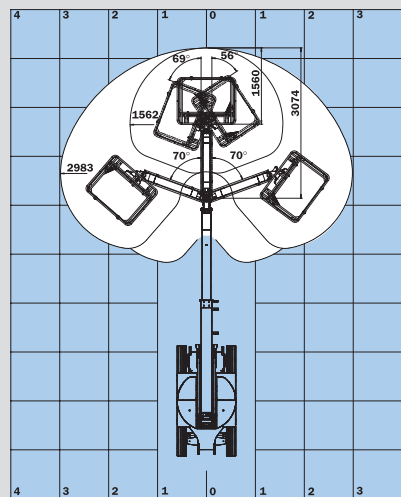

120 AETJ 3D

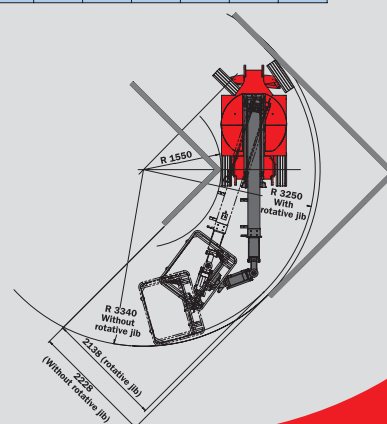
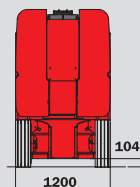
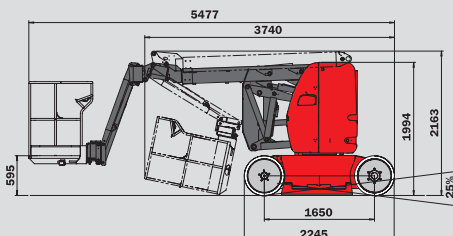

This publication in no way constitutes an offer and the company reserves the right to alter specification without prior notice. The MANITOU models presented in this brochure can be supplied complete with optional equipment attachments.



**MANITOU B.F. S.A.**  
B.P.249 - 44158 ANCENIS CEDEX - FRANCE  
TEL : 33 2 40 09 10 11  
EXPORT DEPARTMENT FAX : 33 2 40 09 10 97  
www.manitou.com