



PIATTAFORMA PER LAVORO AEREO AUTOCARRATA

TRUCK-MOUNTED AERIAL LIFT WORK PLATFORM

HUBARBEITSBÜHNE AUF LKW



PNT200H

isoli@isoli.com | www.isoli.com





DIMENSIONI / OVERALL DIMENSION / GESAMTABMESSUNGEN [mm]

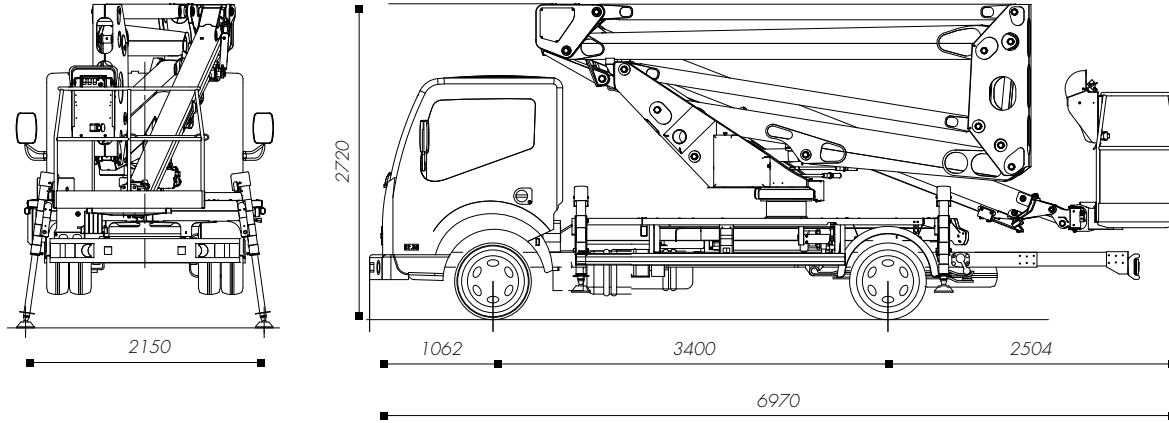

DIAGRAMMA DI LAVORO / WORKING DIAGRAM / ARBEITSDIAGRAMM [m]

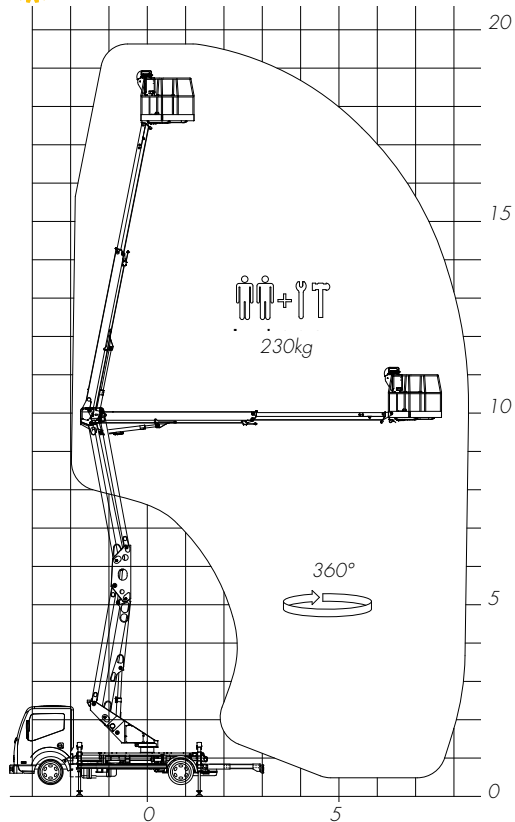

CARATTERISTICHE TECNICHE / TECHNICAL FEATURES / TECHNISCHE EIGENSCHAFTEN

	Altezza max. di lavoro Max. working height Max. Arbeitshöhe	19,7 m
	Sbraccio max. di lavoro Max. working boom extension Max. Reichweite	8,5 m
	Portata Capacity Traglast	230 Kg
	N. operatori N. operators Anzahl Personen	2
	Altezza piano calpestio Walk-on surface height Korbbodenhöhe	17,9 m
	Rotazione sovrastruttura Upperstructure rotation Drehung Oberwagen	400°
	Cesta Basket Arbeitskorb	Alluminio 1400x715x1115 mm Aluminium 1400x715x1115 mm Aluminium 1400x715x1115 mm
	Stabilizzatori Outriggers Abstützungen	Verticale H-H sagoma Vertical stabilisation HH in folded position Vertikale Stabilisierung HH in gefalteter Position
	Comandi Controls Steuerungen	Elettroidraulici Electro-hydraulic Elektrohydraulisch